

Sparklike

THE STANDARD IN GLAZING GAS METRICS

SPARKLIKE HANDHELD

INSTRUCTIONS MANUAL

GAS FILL ANALYZER FOR
WINDOWS AND DOOR



Contents

WARNINGS	3
2 Delivered with Sparklike Handheld	4
3 How does it work?	4
4 How to use Sparklike Handheld	5
4.1 Starting up for the first time	5
4.2 How to use Sparklike Handheld encoder button.	5
5 How to charge the battery.	6
6 Using Sparklike Handheld LCD Screen	7
6.1 Start Up	7
6.2 Logging and storing measurements.	7
6.3 How to create a log file.	8
6.4 How to erase the last logged measurement	8
6.5 How to turn off the LOG mode.	9
6.6 Display contrast	9
6.7 Gas type, Argon or Krypton	10
6.8 Sparklike Handheld only calibrated for Argon.	10
6.9 Change calibration mode to Krypton	10
6.10 Change calibration mode back to Argon	11
6.11 Enabling the PC Connection.	11
6.12 Setting time and date	12
6.13 Sensor test.	12
6.14 Information display.	12
7 Things to consider when taking a measurement.	13
7.1 High voltage	13
7.2 Light	13
7.3 In brief, factors to consider when measuring.	14
8 How to perform a measurement.	14
8.1 Restrictions	16
9 Troubleshooting Sparklike Handheld.	17
9.1 Errors when measuring	17
10 How to connect to a PC	18
11 How to install Sparklike Handheld PC software (Win XP).	19
11.1 Installing the USB <-> Serial Converter.	19
12 Installing the PC software	24
13 How to find and set the right COM port from the PC.	28
14 How to use Sparklike Handheld PC software.	30
15 Troubleshooting the PC software.	34
16 Registering as a Sparklike device user	35
17 Annual Calibration of Sparklike Handheld with Sparklike CARE	36
18 Checking the calibration.	37
18.1 Calibration check with pre-filled IG units	37
18.2 Checking the calibration with premixed gas.	39
19 Appendix A: Sparklike Argon Calibration.	40
19.1 Accuracy of the device:	40
20 Appendix B: Sparklike Krypton Calibration	41
20.1 Krypton Accuracy Limits	41
22 Appendix C: Technical specifications	42
23 Appendix D: Assurance of conformity	43

WARNINGS!

- The instrument uses high voltage. The instrument should NEVER be used near computers nor other sensitive electronic devices.
- Persons with heart conditions or who use pacemakers should not use this instrument.
- The high voltage discharge should never be directed at humans or at animals either directly or through a conductive material such as wires or metal structures.
- Sparklike Handheld device is designed to measure ONLY inert gas combinations such as Argon, Krypton combined with natural Air (78% Nitrogen, 20,9% Oxygen, 0,9% Argon + <1% other natural Air components) located within insulating glass units.
- Sparklike Handheld should NEVER be used to measure any flammable substances nor be used in any flammable environment. Also make sure the insulating glass unit does not contain any flammable substances. (As an example of such substances, Isopropanol, Alcohol, Acentone, Xylen, Thinner).
- The instrument should never be used in wet or in humid conditions.
- Never use the instrument while standing on unsteady surfaces.
- The instrument is a precision measuring instrument and should be handled accordingly. HANDLE WITH CARE!
- Make sure that the front optics of the device is not scratched nor contaminated with dirt.
- Do not clean the front optics. Contact manufacturer before interfering with the front optics in any way. The calibrations might be void in case of interfering.
- The device is not water proof. Do not clean nor let the device come in contact with liquids of any form. The outer shell of the device might be cleaned with a slightly moist tissue (not optics). Do not use any kind of cleaning substances other than those suggested by the manufacturer.
- Always turn off the power when instrument is not in use.
- Keep fingers and other body parts clear of the high voltage area when in use. Do not keep the device connected to your PC nor other electronic devices while performing measurements.
- Do not allow the battery to discharge completely before recharging.
- Do not open Sparklike Handheld casing. In such case calibration is void and no safety guarantee can be granted.
- Do not penetrate the casing with any metallic object nor other objects.
- Do not use any other battery charger than the charger provided by the manufacturer.
- Do not charge the battery by any other means than with the charger provided.
- Do not use any other power source for Sparklike Handheld than the battery provided.

2 Delivered with Sparklike Handheld

1. Sparklike Handheld Device
2. Neck strap
3. CD with software and instructions
4. Calibration data and fast instructions
5. Battery
6. USB Cable
7. Battery charger and power cord
8. Carry case
9. Protective cap



3 How does it work?

A high voltage spark (1) is ignited inside the IG unit (A). This high voltage spark causes the argon atom to emit light to a spectrometer (2), which measures the light. A microprocessor (3) interprets the information of the spectrometer and calculates an argon percent, which it outputs to a display (4).

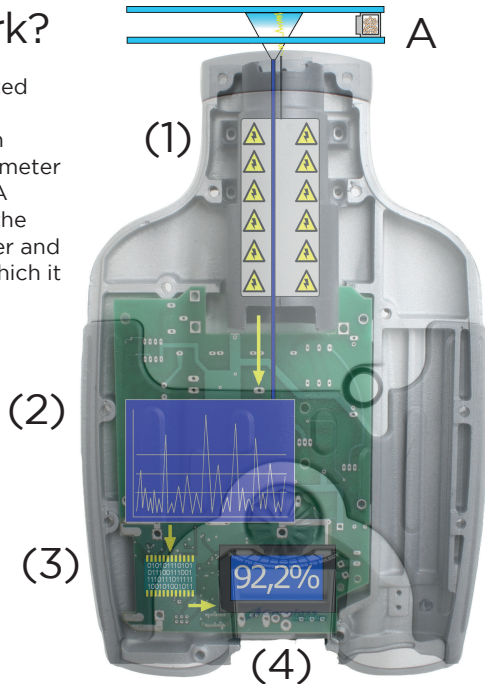

4 How to Sparklike Handheld

4.1 Starting up for the first time



1. Open the battery hatch



2. Insert the battery
3. Connect the battery cable to the socket



4. Power the device on using the ON/Off switch



5. Device settings will be displayed on the screen.



6. The device is now ready for use.

Note!

Read all warnings before the device is taken in use.

4.2 How to use Sparklike Handheld encoder button



Press down to:

1. Enter MENU
2. Confirm a selection



Turn to:

1. Scroll in the MENU
2. Name a log file

5 How to charge the battery

Sparklike Handheld uses a Li-ion battery as main power supply. The battery can only be charged when connected to Sparklike Handheld. The device is also provided with an integrated back up battery that enables Sparklike Handheld to contain all data stored and maintaining a current time and date even if the main battery runs out. Sparklike Handheld battery is designed so that it will be possible to perform measurements for approximately 8 hours before the battery runs out. This is naturally depending on the frequency of use. The charging time for an empty battery is approximately 2 hours.



1. Connect the provided charger to Sparklike Handheld.



2. A red light on the charger module will light when the battery is being charged. See picture

3. The light will turn green when the battery is fully charged.

4. Charging time is approximately 2h hours.

5. CHARGING ... Will be displayed when the battery is charged.

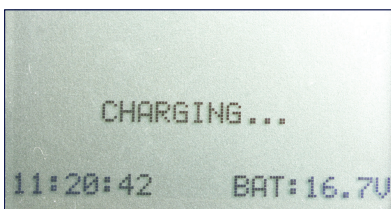

NOTE!

Use **ONLY** the battery charger provided by the manufacturer. If any other charger is used, it may cause the battery to **EXPLODE**.

NOTE!

The charging level must be less than 16.2V (can be seen on the screen) for the charger to start the charging process.

NOTE!

Li-ion batteries have a much shorter life cycle than expected for the device itself and it might be that the user has to replace the battery after some time.

6 Using Sparklike Handheld LCD Screen

6.1 Start Up

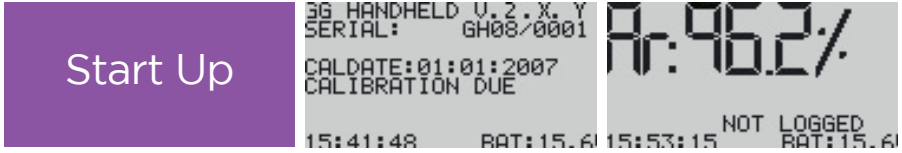

1. When the device is initially powered on, Sparklike Handheld will run a short, self-diagnosis.
2. Once the self-diagnosis has been completed, the display will show the device information screen.
3. The information screen shows:
 - Revision of the software
 - Last calibration date
 - Current time
 - Battery charge status
4. Device is now ready to use
5. When the button is pressed for the first time after start up, the measurement result will show.
6. The current time and battery charge status can be seen on the screen.
7. The LCD display will also indicate if the measurement has not been recorded to the log memory. (See, "How to create a log file")

6.2 Logging and storing measurements.

Sparklike Handheld has the ability to log (store) approximately 1900 measurements.

Logging the data enables:

- a. To store each measurement set as a separate log file
- b. To store a number of different log files containing several measurements. (One log file can contain several measurements)
- c. To measure along the day, review and edit the data at a later stage
- d. To name individual log files (only numbers can be used)

6.3 How to create a log file

```
EXIT
> LOG ON/OFF
  DISPLAY CONTRAST
  GASTYPE
  PC-CONNECT
  -----
  MAIN MENU
```

1. From the main menu, scroll by turning the encoder button to the LOG ON/OFF menu

2. Pressing down on the encoder button will make the selection and the display will show the DATALOGGING menu.

```
DATALOGGING: ON
FILE NR:0008
15:54:14   BAT:15.6V
```

3. When a new log is created, the DATALOGGING menu will automatically advance the log file number by one.

4. Turning the encoder button will increase or decrease the log number. Press down on the encoder button to confirm a selection.

```
A: 96.4%
LOGGING:0010
15:55:15   BAT:15.6V
```

5. "LOGGING," followed by the log number, will be displayed under a reading when the logging feature is enabled.

NOTE! There can be several log files with the same name.

6.4 How to erase the last logged measurement

When the log mode is on and a measurement has been taken but the operator feels that the measurement was an error measurement, it is possible to erase this measurement. This is done to prevent faulty log files on the PC.

```
A: 96.4%
LOGGING:0010
15:55:15   BAT:15.6V
```

1. The measurement is not satisfactory.



2. Press and hold the encoder button for at least 2 seconds.

3. The log value will be deleted permanently.

6.5 How to turn off the LOG mode

```
EXIT
> LOG ON/OFF
  DISPLAY CONTRAST
  GASTYPE
  PC-CONNECT
-----
MAIN MENU
```

1. From the main menu, scroll by turning the encoder button to the LOG ON/OFF menu.

```
DATALOGGING OFF

15:54:30    BAT:15.6V
```

2. Pressing down on the encoder button will make the selection and the display will show, "DATA-LOGGING OFF".

```
A: 96.2%

15:53:15    NOT LOGGED
            BAT:15.6V
```

4. With datalogging turned off, "NOT LOGGED" will be displayed after every measurement.

5. To create a new log file with a new name, repeat the procedure explained in 11.

NOTE! When Sparklike Handheld is connected to the PC and the log files have been retrieved, the log memory will be deleted from Sparklike Handheld device. Using Sparklike Handheld software is the only way to completely empty the memory. This should be done periodically to prevent the memory from exceeding its maximum storage capacity.

6.6 Display contrast

```
EXIT
> LOG ON/OFF
  DISPLAY CONTRAST
  GASTYPE
  PC-CONNECT
-----
MAIN MENU
```

1. From the main menu scroll, by turning the encoder button, to the DISPLAY MODE menu.

2. Select this by pressing the encoder button once.

```
CHANGE CONTRAST BY
<-TURNING ENCODER->

PRESS ENCODER TO EXIT
```

3. Turn the encoder button to adjust the contrast of the screen to desired level.

4. Press down the encoder to confirm choice and exit display mode.

6.7 Gas type, Argon or Krypton

Sparklike Handheld can be calibrated for both Argon and Krypton. The calibration is done by the manufacturer and the user has therefore to inform the manufacturer about this when ordering a device. The device comes standard with a Argon calibration.

6.8 Sparklike Handheld only calibrated for Argon.

```
EXIT
LOG ON/OFF
DISPLAY CONTRAST
> GASTYPE
PC-CONNECT
-----
MAIN MENU
```

1. From the main menu scroll, by turning the encoder button to the GASTYPE menu
2. Select by pressing the encoder button once.

```
ONLY ARGON
INSTALLED

16:04:06    BAT:15.5U
```

3. A screen will display that only an Argon calibration is installed.
4. The display will return to main menu.

6.9 Change calibration mode to Krypton

```
EXIT
LOG ON/OFF
DISPLAY CONTRAST
> GASTYPE
PC-CONNECT
-----
MAIN MENU
```

1. From the main menu scroll, by turning the encoder button to the GASTYPE menu
2. Select by pressing the encoder button once.

```
CHANGED INTO
KRYPTON

16:04:25    BAT:15.6U
```

3. A screen will display that the calibration has been changed to krypton.
4. When measuring the measurement header will be Kr:

Kr 94,2%

indicating that the measurement is in Krypton mode.

6.10 Change calibration mode back to Argon

```
EXIT
LOG ON/OFF
DISPLAY CONTRAST
> GASTYPE
PC-CONNECT
-----
MAIN MENU
```

1. From the main menu scroll, by turning the encoder button to the GASTYPE menu
2. Select by pressing the encoder button once.

```
CHANGED INTO
ARGON

16:04:42    BAT:15.5V
```

3. A screen will display that the calibration has been changed to Argon.
4. When measuring the measurement header will be Ar:

Ar 94,2%

indicating that the measurement is in Argon mode.

6.11 Enabling the PC Connection

Before Sparklike Handheld log data can be downloaded to a PC, the communication port has to be opened. This must be performed before enabling the connection from the PC.

```
LOG ON/OFF
DISPLAY CONTRAST
GASTYPE
> PC-CONNECT
SETUP MENU...
-----
MAIN MENU
```

1. From the main menu scroll by turning the encoder button to the PC-CONNECT menu
2. Pressing down on the encoder button will make the selection and the display will show, "PC-CONNECTION ENABLED".

```
PC-COMMUNICATION
ENABLED

15:46:17    BAT:15.6V
```

3. A screen will display that the PC communication is enabled.
4. The Sparklike Handheld is open for communication with the PC.

To set up PC for communication, see chapter 9.

6.12 Setting time and date



The device date and time can be set by entering the menu, selecting setup menu and 'Set time and date'. Turn encoder button to set year and press it to move on. In a similar way, set month, day, hours, minutes and seconds.

6.13 Sensor test



When contacting Sparklike service, you may be asked to record the sensor information to check the sensor functionality on site. This is done as follows: Enter the setup menu and select 'SENSOR TEST'. After the device shows text 'MEASURE NOW', perform a single measurement on 80% Argon or above recommended window. Check that the spark hits directly through the window. Record all the numbers on the screen and send them to Sparklike service.

6.14 Information display

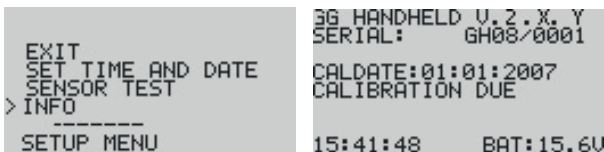

You can retrieve the device serial number and calibration information through SETUP->INFO.

7 Things to consider when taking a measurement

To be able to use the instrument in the best way there are some factors influencing the measurement that should be considered. Sparklike Handheld requires two main things; LIGHT (Optics) and HIGH VOLTAGE (Electricity).

If either or both of these factors are disturbed, the measurement might be affected.

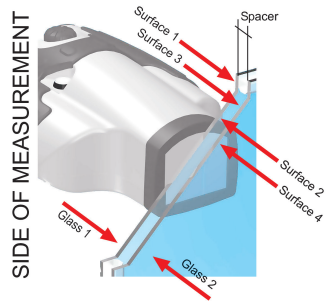

WARNING !!!!!HIGH VOLTAGE!!!!! WARNING

7.1 High voltage

The measurement is made using a high voltage spark. The voltage is approx. 50 000 V but the current is very small. Coming into contact with the spark will sting a little but not harm a normal healthy person even though the instrument MAY NOT be used by a person with a pacemaker or who is in poor physical health. Nor should the spark ever be pointed at any sensitive areas (eyes etc.).

When measuring, the hand unit will create a spark that passes through Glass 1 and ignites inside the air space. Glass is an electrically insulating material, as is air. This means that the spark needs to be strong enough to jump the air gap. In addition to the other electrically insulated materials, such as laminated glass, plastic films, etc. on either side of Glass 1, this makes it even harder to ignite inside the IG.

WARNING !!!!!HIGH VOLTAGE!!!!! WARNING

If there is a metallic coating on Glass 1, it will be impossible for the spark to get through as the metallic film will cause the spark to stay on the surface. Argon gas is a better conductor for the spark than air. This means that the spark actually ignites easier when the fill level is higher. The other thing that helps the spark “jump” is a metallic coating on Glass2, which grounds the spark.

NOTE! NO SPARK DETECTED. Check that spark hits through the window.

7.2 Light

The measurement is dependent on a stable light signal. The light can not be measured if the total light level is too weak or too strong. The total light intensity increases with the background light level as well as with increasing argon percent when measured. If the background light is too strong, e.g. measuring against the sun or a bright lamp, the argon light will “drown” in the sunlight. If the argon concentration is very low, the signal light is very low causing the spectrometer not to see the light.

7.3 In brief, factors to consider when measuring

Factors affecting the optics:

- Coloured glass
- Tinted glass (minimal effect)
- Strong background light (Against the sun or other source)
- Dirt on glass (minimal effect)
- Dirt on the front optical fibre
- Damaged front optical fibre or electrode

Factors affecting the spark:

- Thick glass (over 6 mm)
- Plastic films on Glass 1 (Laminated glass, coatings, etc.)
- Metallic films on Glass 1
- Metallic components in Glass 1
- Low Argon fill (Less than 80%)
- Wide spacer (over 20mm)
- Electrode is not in contact with the glass surface
- Sparklike Handheld is not evenly pressed against the glass.
- Non-metallic spacers

Correct conditions:

- Stable dark background light
- Hand unit NOT moved during measurement

Factors making it easier for the Spark to “jump“:

- High argon fills
- Thin glass (6mm or less)
- Thin air space (20mm or less)
- Metallic or other conductor on surface 3, such as low-e coating
- Metallic spacer bar

8 How to perform a measurement

As described above there are different factors that may affect the measurement result. Sparklike has done extensive research on how to obtain the best possible results when measuring with Sparklike Handheld.

The following procedures are recommended when measuring with Sparklike Handheld.

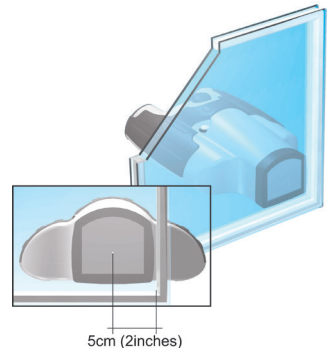

Measure close to the spacer

As the spacer bar of an IG unit is often metallic or contains metal, the spacer bar will help the spark to ignite. It is therefore suggested that the measurement is made close to the spacer. The centre of Sparklike Handheld should be approx. 5cm (2”) from the inner side of the spacer (Approx. 10mm from the side of the front piece). There is no difference at which height of the IG it is measured.

Measure several times: “Because you can”

When measuring the spark will ignite inside the air space ionizing the gases, leaving the gases ionized for a short period of time. This means that the second measurement will ignite easier and producing a better result. Measuring more than three times on one place may cause the Low-E coating to burn changing the readout of Sparklike Handheld. For repetitive measurements, move the hand unit slightly after two or three measurements.

- 1) Ar=92,2%
- 2) Ar=92,4%
- 3) Ar=82,5%
- 4) Ar=92,7%
- 5) Ar=92,1%

Keep the IG upright

Due to the earth’s magnetic field and the ionization of the gasses, the spark will try to “travel up” during the measurement. This causes the spark to act more erratically than if the IG would be laying flat down. In this way the Low-E is protected better from burning so it is suggested to measure the IG standing up.

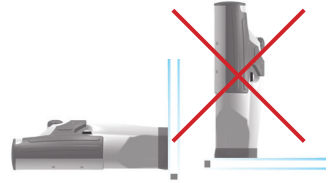

Do not move the hand unit during ONE single measurement

During one measurement cycle two individual measurements are being made; one background measurement and one with the spark on. If the hand unit is being moved during the measurement cycle, the background is altered and the results may not be accurate.

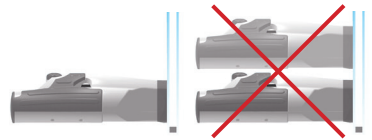

Keep the hand unit flush to the IG unit

If there is space between the spark electrode and the surface of the glass, a big part of the spark burst will occur outside of the IG unit. This means that the instrument is not measuring the spark inside the window but a mix of the inside gas and normal air causing the readings to be too low. The user can easily hear when the hand unit is flush to the IG.

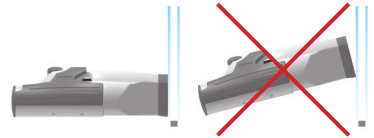

Non Low-E IG units

As the LoW-E coating is metallic, this will act as a ground for the spark. This grounding is being used when the instrument is calibrated. If the window has no Low-E coating, there is no ground to where the spark will ignite producing more erratic readings. These windows should be measured with either a finger on the back of the IG or some other metallic ground for the spark.

8.1 Restrictions

Following is a list of different IG types that can be measured and types that can not or are difficult to measure. There are several conditions that will affect the restrictions. Most of the restrictions are bound to the possibility for the spark to break through and come in contact with the center gas that is to be measured. Any metallic coating (on the side of measurement) will prevent the spark from reaching the gas. A thick glass or a thick lamination will also restrict the spark from going through the element. As Argon and Krypton are good conductors, a high fill level (>80%) will make the process easier. Consult your local distributor or Sparklike for any special types.

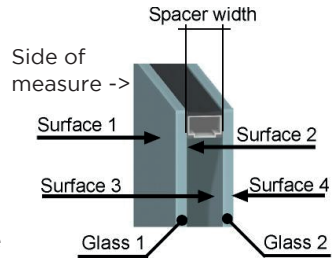

Most of the restrictions are caused by the Glass 1

	Surface 1	Glass1	Surface 2	Spacer	Surface 3	Glass 2	Surface 4
Following is a list of different IG types that can be measured.							
a. IG with glass 1 = clear and surface 3 = LowE							
	Clear	Clear Max.	Clear	Max. 24mm	LowE	N/A	N/A
		6 mm.					
b. IG with glass 1 = Clear and surface 3 = Clear							
	Clear	Clear Max.	Clear	Max. 24mm	Clear	Clear Max	Clear
		6mm				6mm	
c. IG with glass 1 = Toughened and surface 3 = LowE							
	Clear	Tgh Max	Clear	Max 24mm	LowE	N/A	N/A
		6mm					
d. IG with glass 1 = Toughened and surface 3 = Clear							
	Clear	Tgh Max	Clear	Max 24mm	Clear	Clear	Clear
		6mm				Max 6mm	
Following is a list of different IG types that are difficult or can not to measure.							
e. IG with glass 1 = Tinted							
As there are a lot of variations of tinted glass including solar control and different colorizations of the glass there can not be one true rule for this. If the tint includes a metal component it will prevent the spark from breaking trough glass 1 and it will therefore prevent the measurement. As the Gasglass Handheld measures light wavelengths, a coloured glass might also have an effect. Please contact your distributor for these. Otherwise rules applies as for point a.							
f. IG with glass 1 = Laminated							
As the lamination will act as an insulator it will therefore more efficiently prevent the spark from breaking trough glass 1. Therefore there might be difficulties measuring thick laminations. As the Argon and Krypton gas will act as conductor they will therefore make the process easier. In an IG unit where the Argon/Krypton concentration exceeds (>) 85% gas the following general limits can be set.							
	Clear	4+1+4	Clear	Max. 20mm	LowE	N/A	N/A
		Laminated					
g. IG with glass 1 = Frosted							
Same restrictions as for a. and b. depending on LowE coating							
h. Triple glazing							
Due to different compositions of a triple glazing unit there are several that can not be measured as the spark will not reach the insulating gas. As one guideline can be mentioned that if Surface 3 or 4 has an LowE coating and there are no one of the restrictions mentioned earlier, the unit can be measured, otherwise contact your distributor.							

9 Troubleshooting Sparklike Handheld

9.1 Errors when measuring

There are a number of factors that can affect the measurement. When these factors occur an error message or warning message will be shown on the screen. In addition to error/warning message, a scrolling text indicates more precise error message and possible action to resolve the issue.



The measurement accuracy is not specified in the error/warning situations.

The most common messages are:

LOW CONCENTRATION DETECTED. The measured concentration is below 40%. The measured window may have low concentration, no fill or the spark may be measuring air. (Air has 0.9% argon in addition to 78% nitrogen and 21% oxygen.)

WEAK SPARK SIGNAL. The detector cannot see the spark well enough to make a measurement. Check that the spark hits through the window. Try measuring from a slightly different position.

BAD SPARK. Gas percentage cannot be calculated from the spectrum measured. Typically this error message is given when the spark ignites outside the window.

OVEREXPOSURE. The sensor receives too much light during the measurement. Check that there are no bright lights behind the window being measured.

WEAK SIGNAL. The sensor does not receive enough signal. Try measuring again. If the problem persists, there may be an electronics fault that requires service.

NO SPARK DETECTED. The sensor does not receive enough light from the spark. Check that spark hits through the window. If the spark hits to the side spacer, try measuring from a slightly different location so that the spark travels through the window. Check also that the sensor 'eye' in the front piece is clean of dust and dirt.

UNKNOWN WARNING / UNKNOWN ERROR. An unknown error occurred in the measurement, try repeating the measurement. If the problem persists contact your representative.

If Sparklike Handheld shows a warning message, the presented measurement result is only for informational purposes and result should not be trusted.

10 How to connect to a PC

Provided with Sparklike Handheld is a PC software that can be found on the product CD. Please make sure that all needed software and drivers are installed before attempting to connect Sparklike Handheld to the PC.



1. Connect the provided USB cable to the USB socket in Sparklike Handheld

2. Connect the provided USB cable to the PC

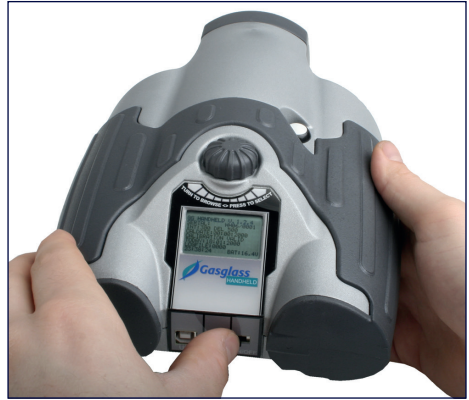

3. Start up Sparklike Handheld



4. Enable the PC connection from Sparklike Handheld.

See: Enabling the PC Connection (6.11)

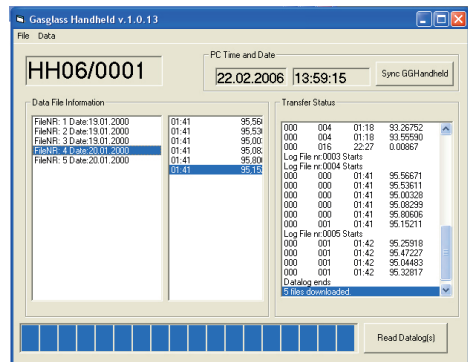

5. Start the PC software

6. Press the “read datalogs”

See: How to use Sparklike Handheld PC software (10)

11 How to install Sparklike Handheld PC software (Win XP)

To be able to use the PC software some additional software needs to be installed. Please follow these instructions in the order that are explained below.

11.1 Installing the USB <-> Serial Converter.

For Sparklike Handheld to be able to communicate with a PC it's needed to create a virtual serial port (COM) from one of the PCs USB ports. With the provided CD there is software that does this.

Please note that the pictures for these instructions are for windows XP and if another version of windows is used, the lay-out may be different.

- A. Insert the Provided CD into the PC
- B. Connect Sparklike Handheld via the provided USB cable to one of the PCs USB sockets.
- C. Turn on Sparklike Handheld
- D. A information box in the bottom of the screen will appear.



- E. The install wizard software will start up automatically. Do not allow windows to search for the drivers.
Tag: No, not this time.

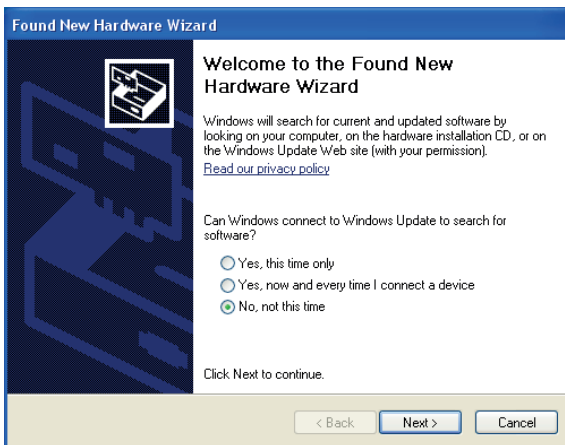

- F. This wizard for installing USB < - > Serial Converter opens up.
Tag; Install the software automatically. NOTE! Insert the CD at this stage.

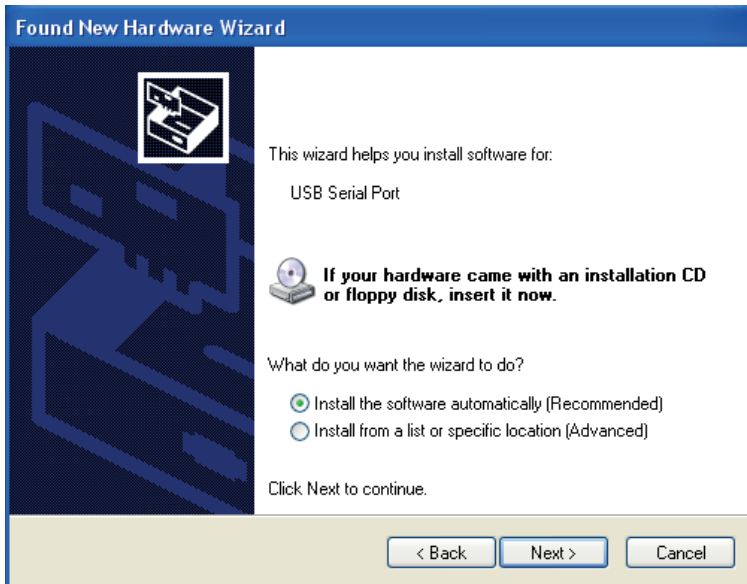

- G. When the installation wizard has found the drivers it was looking for it will start the installation (this might take a few minutes)

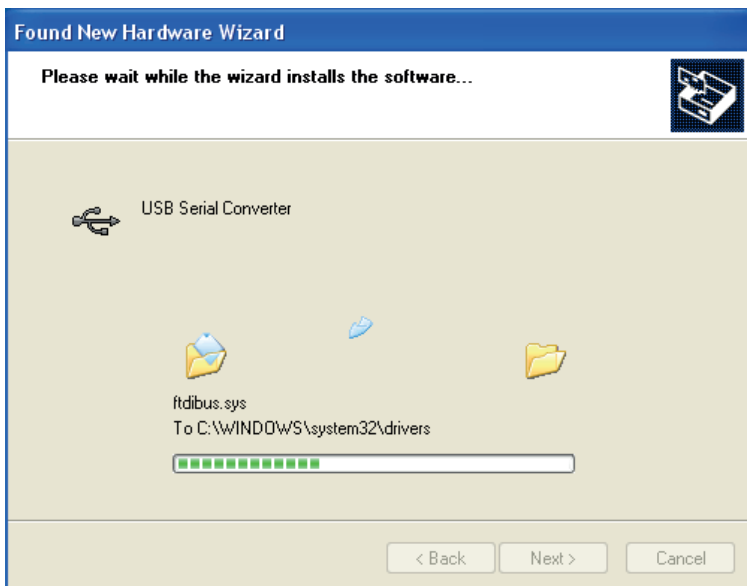

- H. The first stage of the installation is completed. Press finish.

NOTE! The installation will continue.

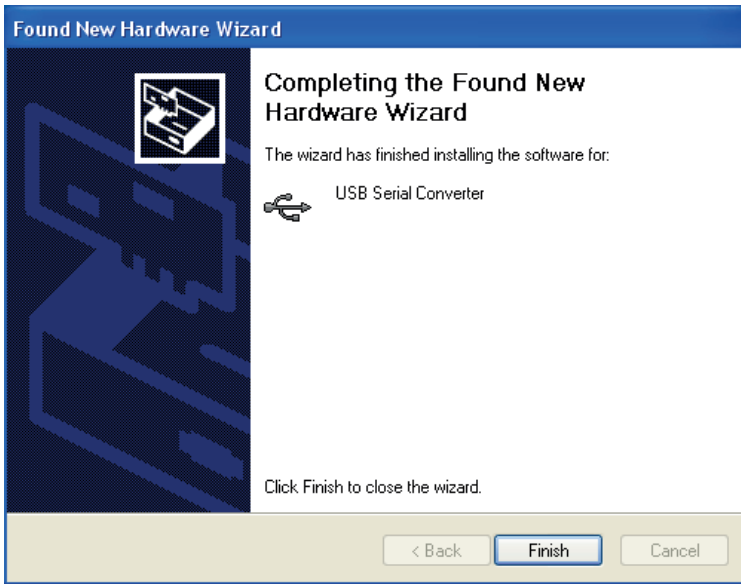

- I. The found new hardware sign will pop up again.

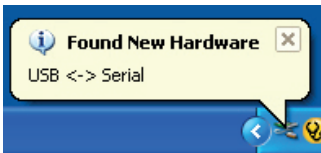

- J. The welcome to install new software wizard will appear. Do not allow windows to search for software. Tag: No, not this time.

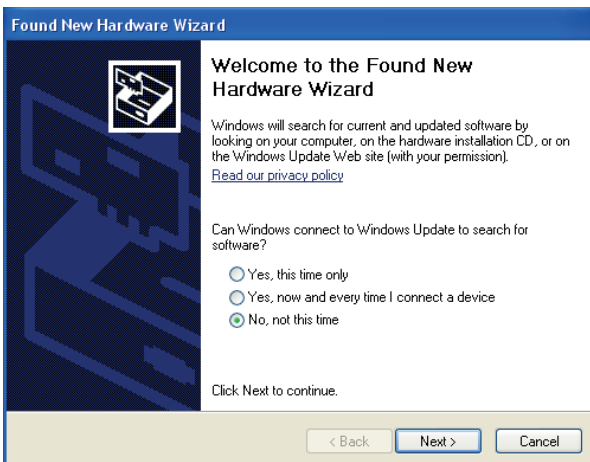

- K. USB Serial Port wizard for installing USB < - > Serial opens up. Tag; Install the software automatically.

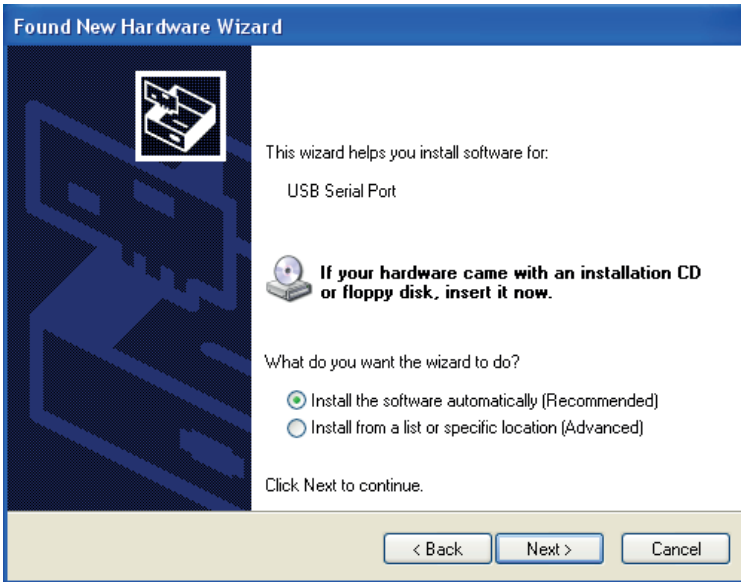

- L. When the installation wizard has found the drivers it was looking for it will start installation (this might take a few minutes)

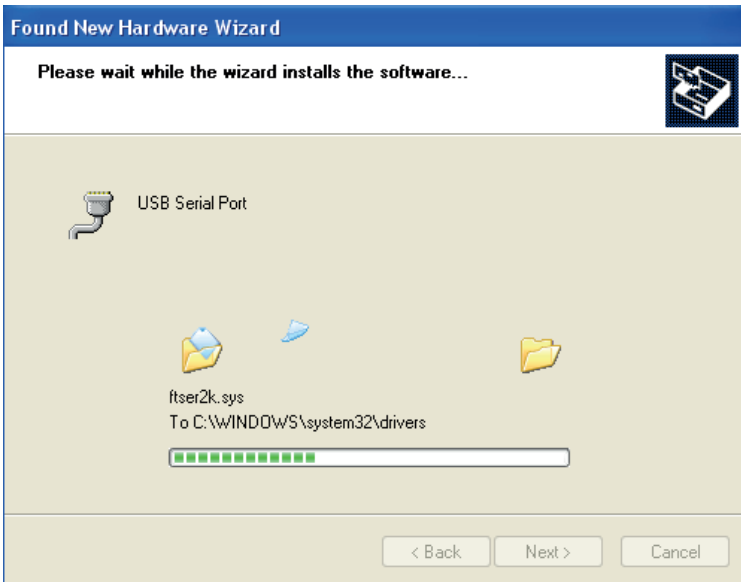

- M. The installation wizard will inform when the installation is completed.

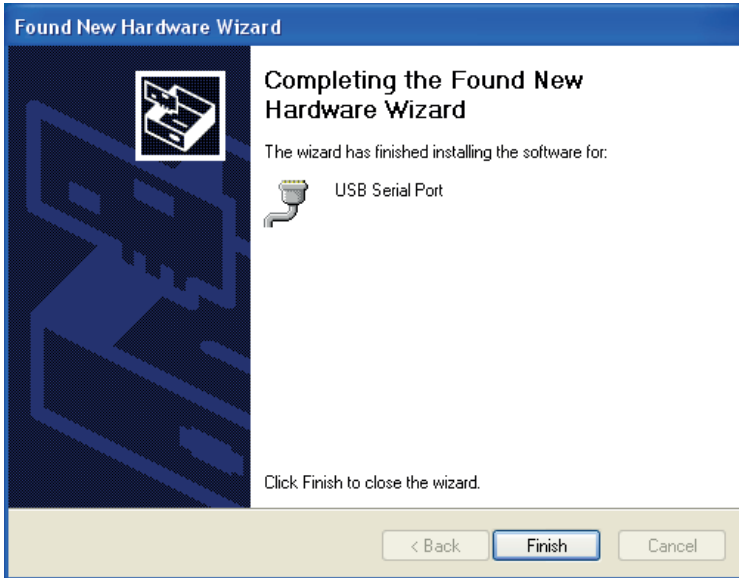

- N. When the installation is completed a message will pop up.

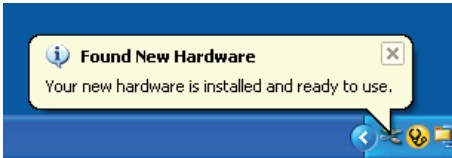

The drivers are now installed on your PC.
Next step will be to install the actual PC software.

12 Installing the PC software

- A. Insert the provided CD. Open it and choose the icon shown below.

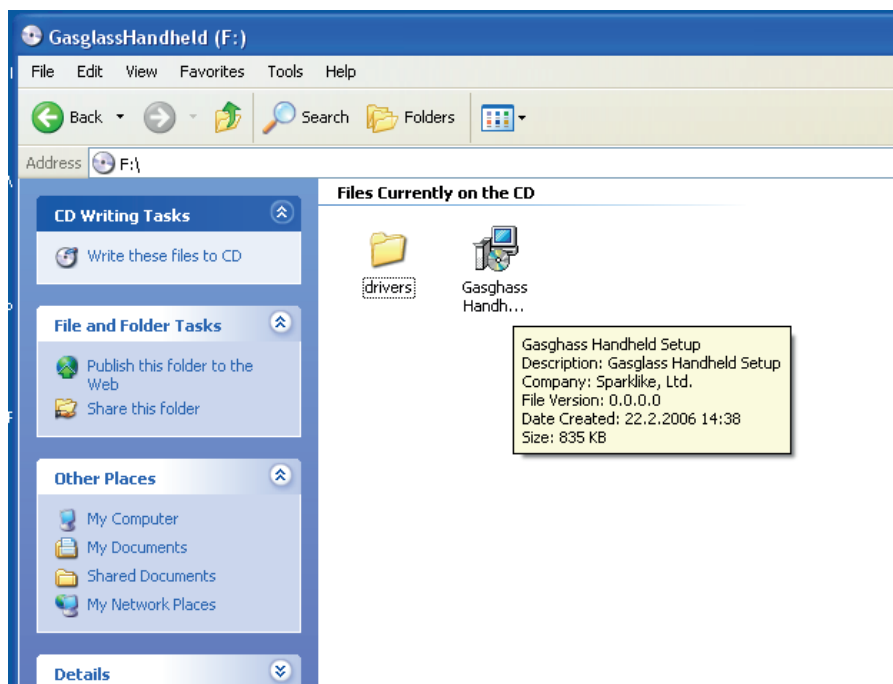

- B. Select the preferred language for the installation.

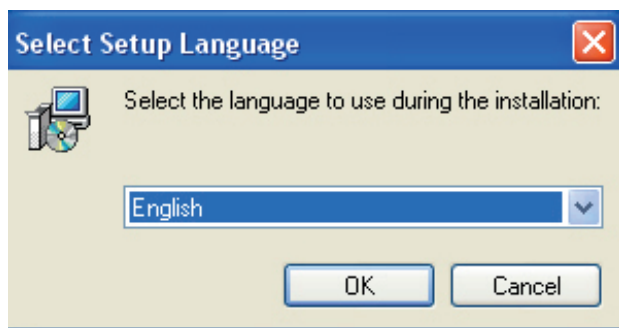

- C. The welcome to installation wizard window will show, click next.

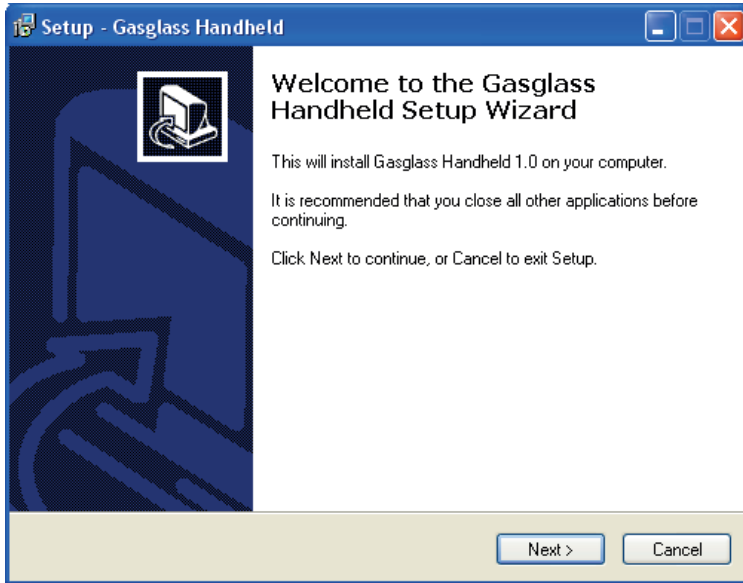

- D. Select the preferred directory where the software is to be installed. The default location is c:\Program Files* which is a normal place to install.

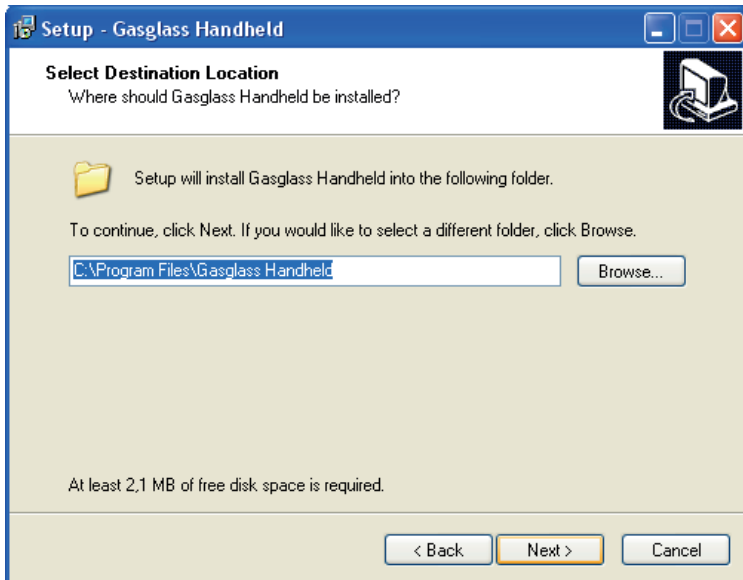

- E. Select the folder name in which the software is to be installed.
Default Sparklike Handheld.

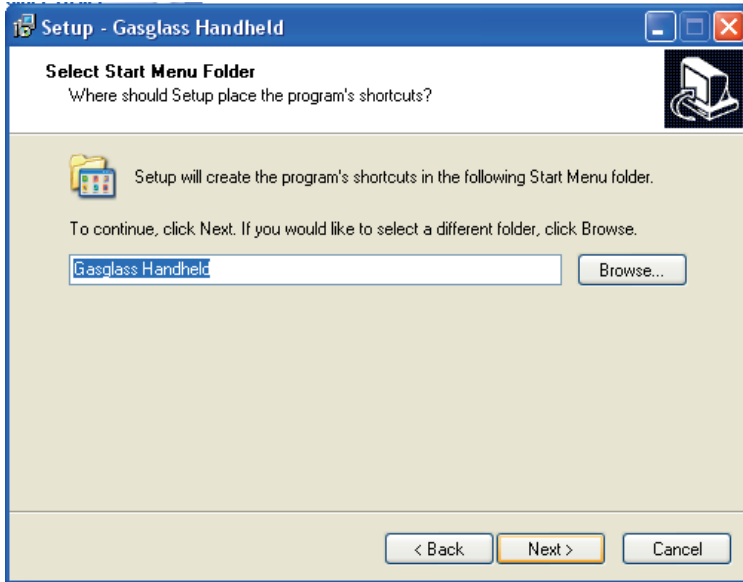

- F. Select the final tasks for the install wizard

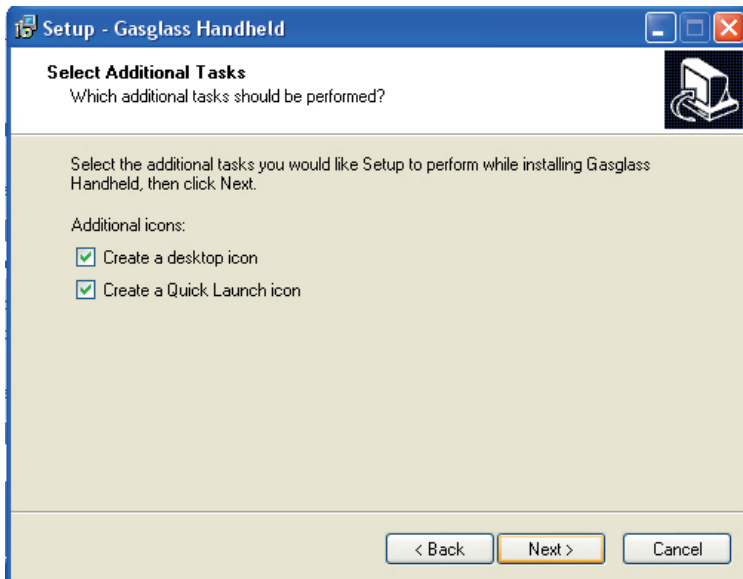

G. The installation is completed



13 How to find and set the right COM port from the PC.

To be able to establish communication between the PC and the Sparklike Handheld, the right COM port must be found. Follow the following steps for this task.

- A. **IMPORTANT.** Connect Sparklike Handheld to the PC and turn Sparklike Handheld on before continuing.
- B. Right click the My Computer icon on the PC. From the menu select Properties

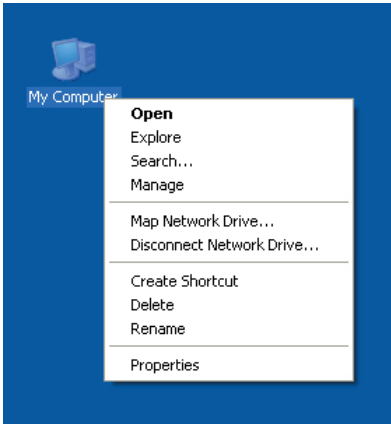

- C. The System Properties window will appear. From the System Properties window select Hardware and under this sheet Device Manager.

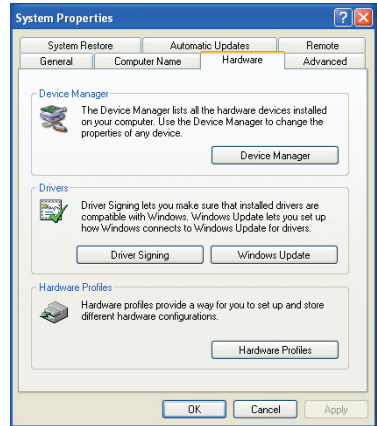

- D. The Device Manager window will appear. From the Device Manager window click the '+' next to Ports (COM & LPT)

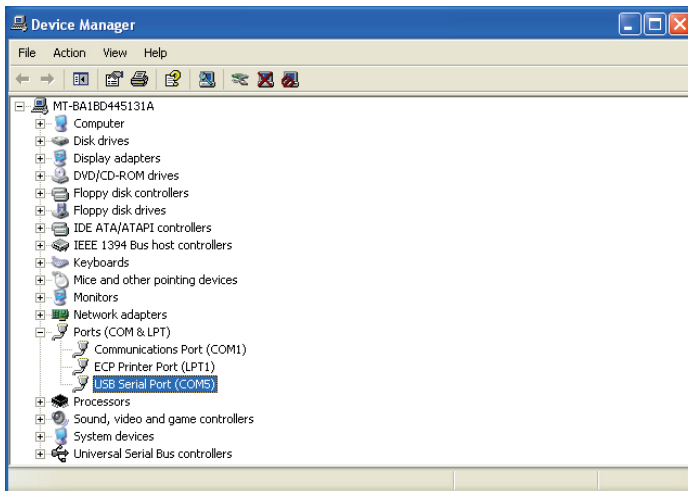

- E. If Sparklike Handheld is correctly connected and installed on the PC a USB Serial Port (COM [number]) will show.

This line shows the COM port number that the Sparklike Handheld uses on this PC. In this example Sparklike Handheld uses COM 5. This number must be entered in Sparklike Handheld software under the File, Settings, Enter COM port. Before using for the first time.

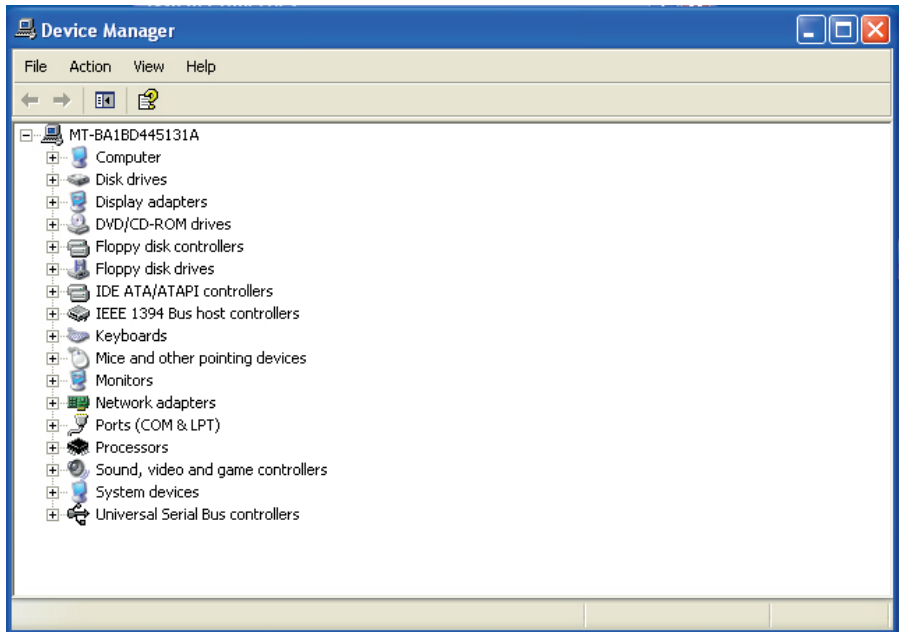

NOTE! The COM port number varies depending on PC.

NOTE! If there is more than one device installed and in use these will all show in this window. These can and will change if the device is connected to a new COM port

NOTE! Double digit COM port numbers are not allowed for data transmission.

14 How to use Sparklike Handheld PC software

Sparklike Handheld software is designed only to handle the logged data from Sparklike Handheld. This means that the software does not have too many features.

A. Starting up the first time.

Please make sure that you have the right settings on the PC software. Important is that the right COM port is selected. See: How to find the right COM port from the PC.

B. Starting up the software

After a successful installation, an icon as below will show in the Desktop. Start up by double clicking the Icon



C. Changing the COM port setting.

From File choose Settings.

D. Change COM port

Fill in the right COM port number and click OK.
See: How to find the right COM port from the PC.

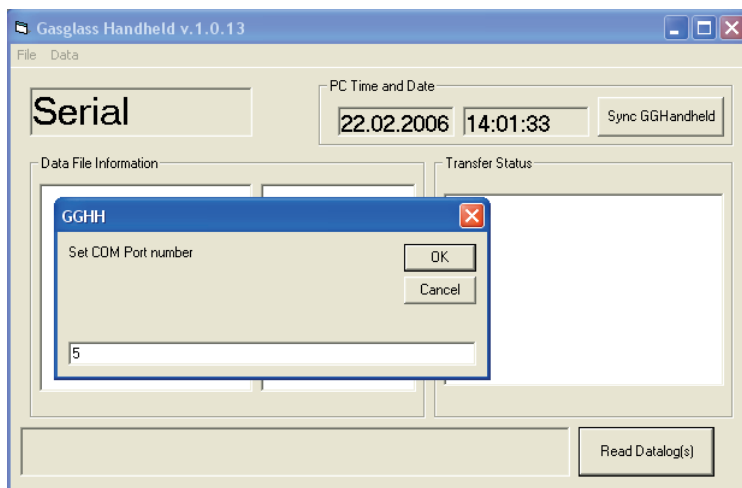
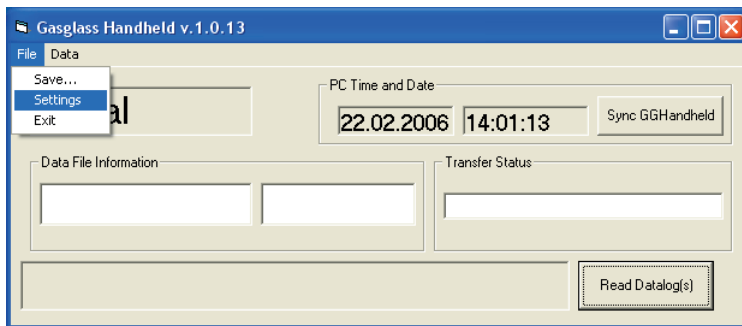

E. Connect Sparklike Handheld to the PC

See: How to connect to a PC

F. To retrieve data from Sparklike Handheld, click Read Data log(s) button

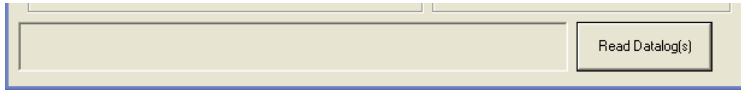

G. After a successful download the window looks as follows. See picture.

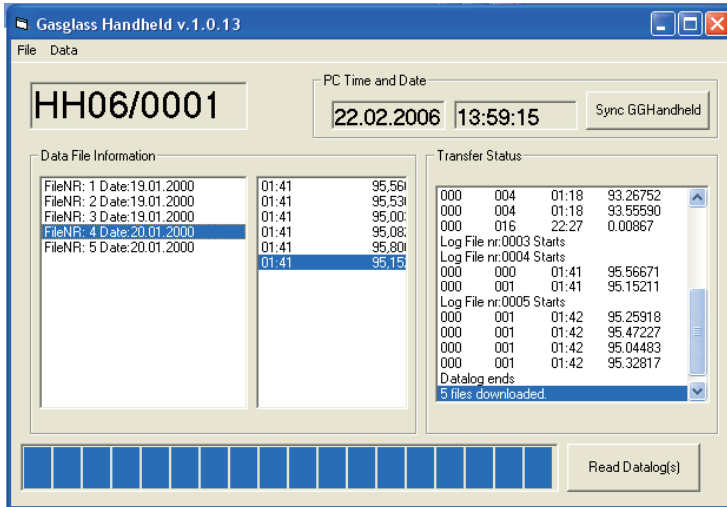

NOTE! Sparklike Handheld needs to be turned on when downloading data.

H. The window contains of the following.

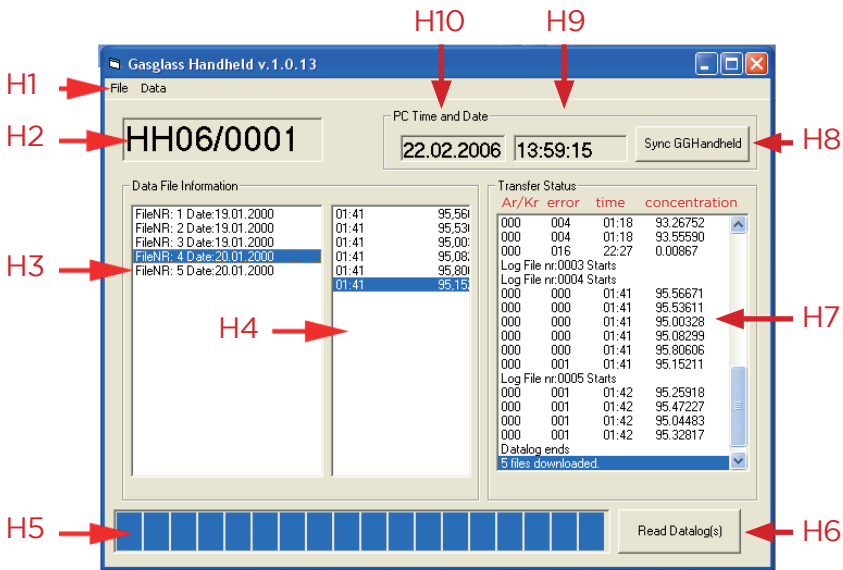

H1. Top menu

H2. The serial number for the connected Sparklike Handheld

H3. All the downloaded log files.
Contains the file name, creation time and date of the log file.

H4. The content of the selected log file.
Will show all the measured data within the selected log file by double clicking the log file.

H5. Download status bar.
Shows the status when downloading data from Sparklike Handheld

H6. Read Data Logs.
This downloads the data from the connected Sparklike Handheld.
See; How to connect to a PC

H7. Downloaded data.
Shows all downloaded data from Sparklike Handheld.

H8. Sync GGHandheld.
Sends the current time and date to Sparklike Handheld. Please check that the time and date settings are correct on the PC. It is important that the time and date is up to date on Sparklike Handheld as this information will show on the downloaded data logs.

NOTE! PC communication needs to be activated from the Sparklike Handheld device.

H9-10. Shows the correct time and date of the PC.

NOTE! Save data before closing software.

H1-a. File / Save

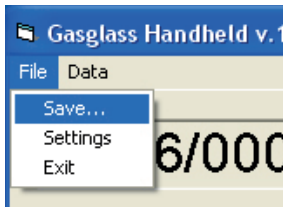

The save command saves all the downloaded data as a *.txt file.

H1-b. File / Settings

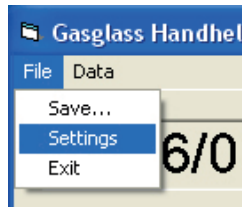

The Settings command allows changing the communication (COM) port between Sparklike Handheld and the PC

H1-d. File / Exit

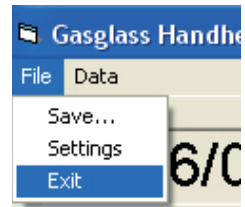

Exit the software. Please save all data before exiting.

H1-c. Change the COM port

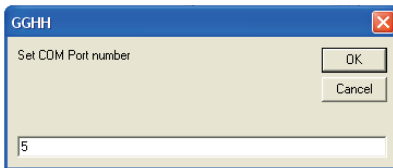

Set the right COM port for communication and press OK.

See: How to find the right COM port from the PC

H1-e. Data / Copy Current Log

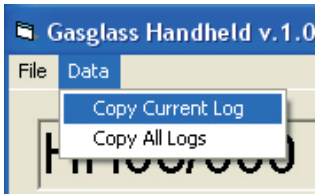

The Copy Current Log command copies the selected log file to the clipboard.

H1-f. Data / Copy all logs

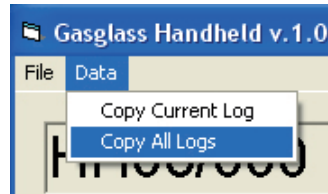

All the downloaded logs will be copied to the clipboard.

H1-f. Data / Copy all logs. Select the log that is to be copied to clipboard.

Only the selected file will be copied to the clipboard.

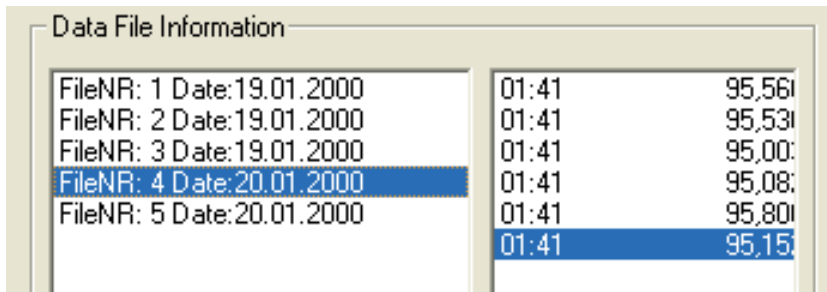

15 Troubleshooting the PC software.

Problem: No data is downloaded from Sparklike Handheld when selecting Read Data Log(s).

Read the messages in the Transfer Status window in the PC software

Message: Data transfer error: invalid port number, opening of COM 6 failed

Actions:

- a. Check that the right COM port is selected.
Please see; How to find the right COM port from the PC
- b. Check that the provided USB cable is connected to the PC and Sparklike Handheld
- c. Check that the Sparklike Handheld turned on
- d. Check that the Sparklike Handheld is in "PC CONNECT" mode.

Message: COM time out

Actions:

- a. Enable PC Connection from Sparklike Handheld
Please see; Using the Sparklike LCD Screen
- b. Check the communication port.

Message: No stored data in Sparklike Handheld

Actions:

- a. There is no stored data in Sparklike Handheld. Make sure that the logging function is turned on in Sparklike Handheld.

Please see: [Using the Sparklike LCD Screen](#)

NOTE! All logged data will be erased from Sparklike Handheld when downloaded to the PC.

Problem: The time and date is wrong on the screen

Actions:

Make sure that the time and date settings are correct on the PC that is in use.

16 Registering as a Sparklike Handheld user

By registering as a Sparklike Handheld user you can make sure that your device is listed in our device register. By registering our after sales can make sure that you are informed about when your device is due for calibration and if there is any updates available. The registration is simply done by sending an email to our after sales where you inform us about the device serial number and your contact information.

Email: aftersales@sparklike.com

17 Annual Calibration of Sparklike Handheld with Sparklike CARE™

The manufacturer suggests that Sparklike Handheld devices are calibrated annually. By performing the calibration every year, the user will make sure that the device works as it should. For more information and online forms, please visit sparklike.com/care

In the calibration process, the device is checked for any faults and will also be cleaned at the same time. Sparklike CARE™ includes the following features:

- the maintenance of the most common wear and tear parts such as battery, optical filters, optical fibre etc.
- the calibration to argon and/or krypton as well as calibration certificate
- pick-up and return of the service
- reminder message one month prior to the need of the calibration
- testing the analyzer at Sparklike Oy testing laboratory
- calibrating to Software updates

The annual calibration steps are as follows:

1. Go to sparklike.com/care to sign up for Sparklike CARE™ and fill in the form online.
2. When the request is received, Sparklike Oy aftersales will inform you about the schedule. The expected calibration time is 2 working days plus time needed for shipment.
3. When confirmation is received, order a pick up to deliver the device to the following address:

Sparklike Oy
Hermannin rantatie 12 A 21
00580 HELSINKI, FINLAND

Please write a note placed within the package that states your return address and contact person.

4. When Sparklike Oy receives the shipment and the device is looked over.
5. When all the actions are taken, the device will be returned to you.

One time calibration without Sparklike CARE™ can be performed by Sparklike Oy or our distributor in USA. For more information, please visit sparklike.com/care-and-maintenance/calibration

18 Checking the calibration

When measuring an IG unit, it is good to follow a certain procedure. The sequence is performed by taking 15 single measurements right after each other for each IG. The measurement spot is also to be changed after each single measurement. Please see picture below for the area within to perform the single measurements. A normal procedure is to take the first measurement at the left top of the unit, taking a total of 15 measurements moving the measurement handle down slightly after each measurement until reaching the bottom of the measurement area. Repeat this on the other side of the unit.

18.1 Calibration check with pre-filled IG units

The calibration check is done by pre-manufacturing a batch of IGUs. The IGUs are to be filled with Argon gas and it is suggested that the concentration exceeds 85% Argon for the test to be reliable. The best concentration level for this is over 90% and under 95% Argon. It is also suggested that at least 5 IGUs, preferably 10 IGUs are made at the same time.

The idea with this test is that it has to be done the first time when the Sparklike Handheld device reaches the customer as in this stage we can be sure that the device is within calibration limits.

E.g. 10 units are produced and measured.

Please follow measurement instructions for each unit.

The result might be as follows:

Write down the measurement results and store them. E.g. on a sticker on the IGU. For best performance the results should be an average of several measurements taken from the same unit.

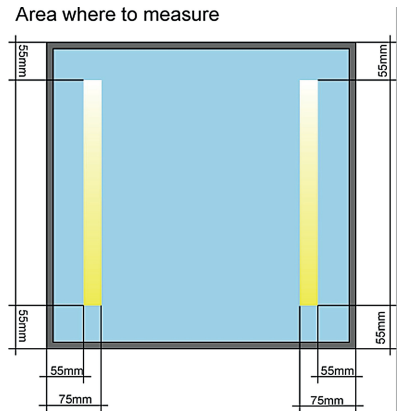

	Day 1
IGU #1	92% Ar
IGU #2	90% Ar
IGU #3	85% Ar
IGU #4	91% Ar
IGU #5	88% Ar
IGU #6	89% Ar
IGU #7	83% Ar
IGU #8	90% Ar
IGU #9	92% Ar
IGU #10	93% Ar

The same 10 IGUs are measured again after 1 week and the result is as follows:

.	Day1	Day 7
IGU #1	92%	91.5% Ar
IGU #2	90%	70% Ar
IGU #3	85%	85% Ar
IGU #4	91%	90.5% Ar
IGU #5	88%	87.5% Ar
IGU #6	89%	73% Ar
IGU #7	83%	82.5% Ar
IGU #8	90%	86% Ar
IGU #9	92%	91% Ar
IGU #10	93%	92.5% Ar

We can see that only for a few IGUs has the percentage changed extensively. Also note that the percentage for these has dropped. From this we can conclude that the Argon has leaked out from these few IGUs. For the other IGUs the percentage has changed only slightly, this can be because of homogenisation within the unit. The change is still so small that it is not to be taken into account. The IGUs that has been leaking is to be changed for new ones.

Again some time has passed and the units are tested again and the results are as follows:

.	Day1	Day 7	Day 30
IGU #1	92%	91.5% Ar	80%
IGU #2	90%	89.5% Ar	50%
IGU #3	85%	85% Ar	70%
IGU #4	91%	90.5% Ar	74%
IGU #5	88%	87.5% Ar	72%
IGU #6	89%	89.5% Ar	71%
IGU #7	83%	82.5% Ar	65%
IGU #8	90%	89.5% Ar	75%
IGU #9	92%	91% Ar	79%
IGU #10	93%	92.5% Ar	78%

We can now see that the ALL the measurements has dropped dramatically. It is possible but not likely that ALL the units have been leaking this much and therefore we can with high confidence suspect that the calibration of Sparklike Handheld has changed.

If the results of the measurements in the previous test would have been as follows:

.	Day1	Day 7	Day 30
IGU #1	92%	91.5% Ar	93%
IGU #2	90%	89.5% Ar	92%
IGU #3	85%	85% Ar	94%
IGU #4	91%	90.5% Ar	95%
IGU #5	88%	87.5% Ar	92%
IGU #6	89%	89.5% Ar	93%
IGU #7	83%	82.5% Ar	92%
IGU #8	90%	89.5% Ar	91%
IGU #9	92%	91% Ar	95%
IGU #10	93%	92.5% Ar	96%

We can see that all the measurement results have risen. This is not THEORETICALLY possible and therefore we can be quite sure that the calibration of Sparklike Handheld has changed.

In the two last cases, please contact your local distributor or Sparklike Oy direct.

18.2 Checking the calibration with premixed gas

One more precise way of checking the calibration of the Sparklike device is using known premixed gas to fill IGUs. The idea of the test is the same as when using pre filled IGUs but the user will know what he should expect from the test results.

The procedure is as follows:

- a. Order premixed gas from you local gas supplier. Suggested mix is 90% Argon and 10% compressed Air.

Note that the mix seldom is exactly what you have ordered. The supplier will state their fill percentage on the bottle. The note will also state a possible error in the mixed gas. Please take this into consideration.

Note also: compressed air consist of 20,9% O2 and 79% N2.

- b. Build a system as the picture to the right shows.
 - Make sure you have an air tight system that will not leak.
 - Make sure that you regulate the in-flowing gas otherwise the IGU will EXPLODE.
 - Regulate the flow to approximately 1 l/minute flow through a diam. 4mm tube.
 - This should be monitored!

- c. Calculate the volume of your IGU

Volume (V) = Width*Height*Depth, result should be in “litres”

- d. Fill the unit

Calculate the time of filling the unit Time to fill (t) = V / Flow

- e. Over fill the unit by at least 4 times

Regardless, unit size, flow it at least 1 minute.

- f. Measure the unit

Let the unit settle after filling for 30 seconds.

Perform the measurement as instructed earlier, see point 2.1

Sparklike Oy. Uses and also suggests an IGU that is of the size:

Width: 350mm
Height: 350mm
Thickness: 12 mm
Glass 1: 4 mm clear float
Spacer: 12 mm (metallic)
Glass 2: 4 mm LowE coating

GASGLASS TEST

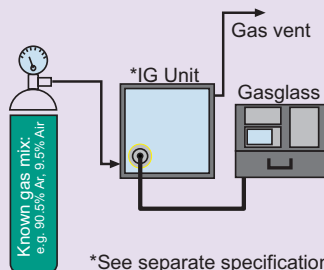

19 Appendix A: Sparklike Handheld Argon Calibration

Sparklike Handheld is factory calibrated to Argon prior to shipment. The calibration is done by measuring the following concentrations of Argon in a 4mm float - 12mm spacer - 4mm Low-E IG unit:

Argon: 97.5%	Air: 2.5%
Argon: 95%	Air: 5%
Argon: 90%	Air: 10%
Argon: 85%	Air: 15%
Argon: 80%	Air: 20%
Argon: 70%	Air: 30%
Argon: 50%	Air: 50%
Argon: 0%	Air: 100%

The original calibration data is provided with the instrument. If Sparklike Handheld is maintained properly the calibration should not change over time. Sparklike Handheld calibration should be tested on a regular basis. If the calibration has changed, please consult your distributor or Sparklike for information on how to change the calibration.

19.1 Accuracy of the device:

The accuracy of Sparklike Handheld is stated to be within the following specifications:

The test unit is measured 15 times. The limits of the difference between the argon concentration (Ar%) in the test unit and the measured average of 15 measurements ($\Delta 15$) are:

Ar%	100	97,5	95	90	85	80	75	70	65	60	50
$\Delta 15$	0,50	0,50	0,50	1,00	2,00	3,00	3,50	3,50	3,50	3,50	3,50

The standard deviation first confidence interval (68% of the readings) must also fit inside the limits. The lowest measurable concentration is approximately 50%

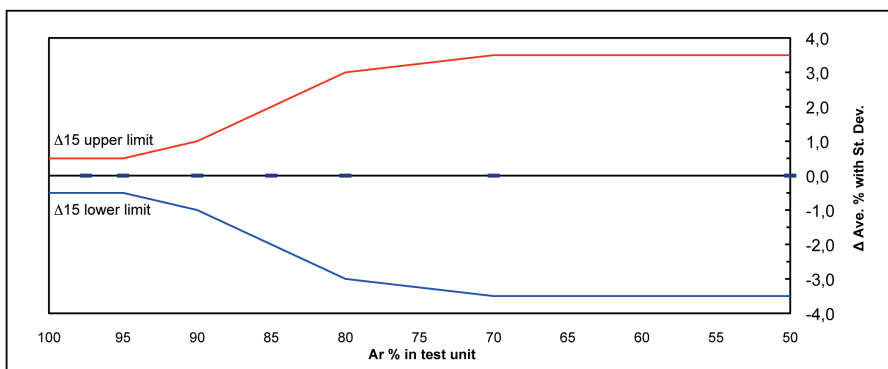

NOTE! Lowest measurable concentration is approx. 50%
NOTE! The accuracy is tested to be according to the specifications at the time of shipping for a 4-12-4Low-E IG unit.

20 Appendix B: Sparklike Handheld Krypton Calibration

The foundation for Sparklike Handheld is laid by a very extensive research for the detection of Argon concentrations. As a side result of this the Krypton measurement feature was achieved. Therefore the calibration for Krypton will not be as accurate as the Argon calibration, neither will the field of use be the same. As several customers has asked for this feature, Sparklike Oy decided to provide this feature, though on a different accuracy level than the Argon calibration. This document gives an indication on what the actual accuracy and fields of use is for the Krypton calibration.

20.1 Krypton Accuracy Limits

In the graph below the standard deviation limits can be seen for Krypton calibration.

Test Unit: 4-12-4 Optitherm SN LowE

Size: 350*350 mm

Spacer bar: 12 mm Aluminium

Primary sealant: Polyisobutylene

Secondary sealant: Polysulfide

Kr%	100	95	90	85	80
$\Delta 15$	1.0	1.0	2.0	5.0	5.0

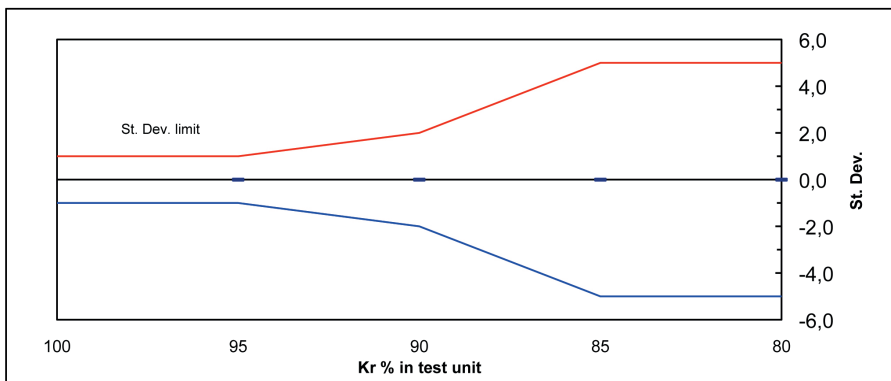

NOTE: The accuracy of the Sparklike Handheld is measured for the above mentioned IG only*. If the IG type differs from this, the accuracy is not guaranteed. The Sparklike Handheld instrument may show slightly different readings depending on the kind of IG units currently being measured.

22 Appendix C: Technical specifications

Overall Dimensions:	265*190*90 mm
Weight:	2 kg
Operating Conditions:	+10° — +35° C
Humidity:	0 - 90 % R.H. Non-condensing
Main Power Supply:	16,8 V Li-ion battery, 2 Ah
Power Consumption:	40 W
Battery Charger:	Li-ion battery charger, 4 cells
Connections:	USB and Battery charging
Display:	128*64 pixel LCD display
Measurement time:	1s
Software:	Sparklike Handheld data logging software for PC and communication drivers.
Data logging capability:	Approximately 1900 measurements

Manufacturer:



Sparklike

SPARKLIKE OY

Address: Hermannin rantatie 12 A 21
00580, Helsinki, FINLAND
Phone: +358 10 387 7701
Fax: +358 10 387 7707
Email: sparklike@sparklike.com
Web: www.sparklike.com

23 Appendix D: Assurance of conformity

ASSURANCE OF CONFORMITY	
We hereby assure that the electrical device manufactured by Sparklike Ltd. complies with the EMC directive 2004/108/EC on electromagnetic compatibility.	
Manufacturer:	Sparklike, Ltd.
Contact information:	Särkiniementie 5 C 6, FI-00210, Helsinki, Finland tel. +358 10 387 7701, fax +358 10 387 7707 email: sparklike@sparklike.com
Product:	Instrument for measuring insulating gases in insulated glazing units without having to break them. Available accessories include battery and CE certified charger.
Commercial name of the device:	Gasglass-Handheld
Serial number:	Serial number format (example): "GH07/0137" where the letters "GGHH" indicate that the device in question is Gasglass Handheld. The two numerals after the letters refer to the year of manufacture, e.g. "07" to the year 2007. The number "0137" indicates the individual running serial number of the device.
The structure of this device complies with the following universal standards:	
EMC The device complies with all the appropriate requirements of the EMC directive as specified in our technical construction file "Gasglass Handheld". The EMC section of the technical construction file has been approved by accredited EMC testing and certification company SGS Fimko Oy in its report TFR 246 880-2 (4 June 2007). The device has been CE certified in 2007.	
 Helsinki, on the 3 rd of October, 2007, Sparklike Oy, Mats Therman, Managing Director	

Sparklike, Ltd

Address: Särkiniementie 5 C 6, 00210, Helsinki, Finland
Email: sparklike@sparklike.com
Web: www.sparklike.com
Phone: +358 10 387 77 01



Sparklike

SPARKLIKE OY

Address: Hermannin rantatie 12 A 21
00580, Helsinki, FINLAND
Phone: +358 10 387 7701
Fax: +358 10 387 7707
Email: sparklike@sparklike.com
Web: www.sparklike.com

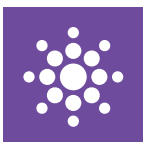

Sparklike

SPARKLIKE OY

Address: Hermannin rantatie 12 A 21
00580, Helsinki, FINLAND

Phone: +358 10 387 7701

Fax: +358 10 387 7707

Email: sparklike@sparklike.com

Web: www.sparklike.com